



---

Manual for  
drilling motor

**230 V**

**EBM 33**  
**EBM 33 F**  
**EBM 33 S**

---

Valid from 03.2018

Art.-Nr. 200940  
200942  
200944

Subject to alterations

---



---

All rights reserved

## Conformity Declaration

# DR.BENDER GmbH

Innovative Elektrowerkzeuge



### EC declaration of conformity (EG-RL 2006/42/EG)

Hereby the manufacturer

Dr. Bender GmbH  
Industriestrasse 22  
75382 Althengstett

declares for the products

**EBM 33, EBM 33 F, EBM 33 S**

The named product conforms to the following Council Directives on approximation of laws of the EEC Member States:

- Council Directive for machinery (2006/42/EC)
- Council Directive for Electromagnetic compatibility (EMC) (2004/108/EG)
- Low Voltage Guide Lines (2006/95/EG)

Conformity with the requirements of this Directives is testified by complete adherence to the following standards:

EN 50144-1  
EN 50144-2-1  
EN 55014-1  
EN 61000-3-2  
EN 61000-3-3  
EN 55014-2  
EN 61029-1

The instructions contained in the operating manual for installation and start up the machine have to be followed.

Authorised Person for Documentation:

Min Wei  
c/o Dr. Bender GmbH  
Industriestrasse 22  
75382 Althengstett  
Deutschland

DR.BENDER GmbH  
Industriestraße 22  
D-75382 Althengstett  
Tel. 07051/9291-0, Fax 07051/9291-91

Althengstett, 30.07.2018

Min Wei, Managing Director

This Declaration does not include Assurance of Product Properties.  
The Safety Instructions of the enclosed Product Documentation have to be respected.

# Contents

	page
Conformity declaration	2
Contents	3
1.0 Symbol- and Pictograph description	4
1.1 Function description	4
2.0 General instructions	5
2.1 Application	5
2.2 Safety	5
3.0 Transport and storage	6
3.1 Transport	6
3.2 Storage	6
4.0 Main dimensions and technical data	7
4.1 Dimensions	7
4.2 Technical data	7
4.3 Noise emissions and vibrations [EN 50144]	8
5.0 Commissioning	8
5.1 Changing gear	9
5.2 Safety coupling	9
5.3 Core bits	9
5.4 To change a core bit	9
6.0 Safety instructions	10
7.0 Servicing and care	11
7.1 Daily care	11
7.2 After approx. 150 hours of use	11
7.3 After approx. 250 hours of use	11
7.4 Quarterly	11
8.0 Speed adjustment dependent on the cutting speed	12
9.0 Warranty	13
10.0 General safety instructions	14
11.0 Spare parts list	16
11.1 Stone drilling machine complete EBM 33	16
11.2 Stone drilling machine complete EBM 33 F	18
11.3 Stone drilling machine complete EBM 33 S	20
11.4 Motor complete EBM 33	22
11.5 Motor complete EBM 33 F	24
11.6 Motor complete EBM 33 S	26
11.7 Gear complete	28
11.8 Connection cables and accessories	30



## Warning

The safety instructions set out in this operating manual must be followed at all costs.

Special designs and versions may differ from the standard models in terms of their technical details. If any points are unclear, we urgently recommend that you contact DR.BENDER GmbH, indicating the machine type and machine number.

### 1.0 Symbol- and Pictograph description



This sign tells you rules, if you not pay attention for this your health and the function of the machine is in danger. You have no warranty if the machine breaks down because you not looking about this.

### 1.1 Function description

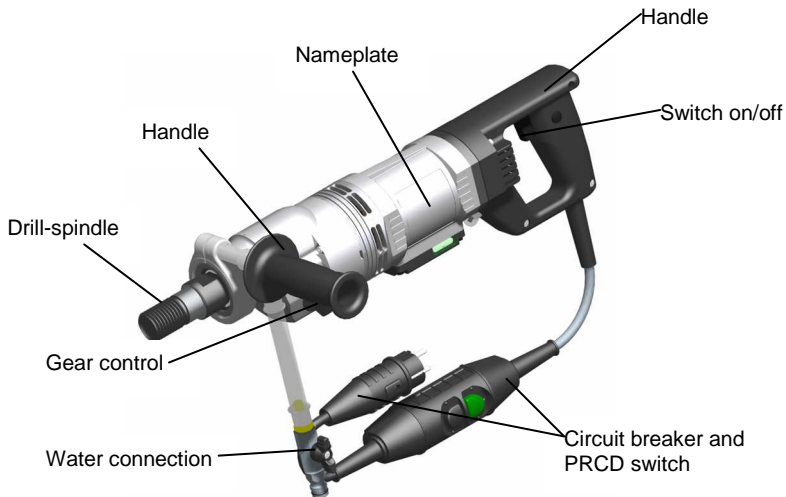

## 2.0 General instructions

### 2.1 Application

The core drills can be used for the purposes outlined by the data on the model plate. If you are using special machines, the details in the quotation and order confirmation also apply.

The core drills are supplied as standard in protection class I, only this can guarantee the full high quality production of the residual current-operated circuit-breaker or PRCD switch.

If you use suitable core bits, you will be able to drill holes in the most diverse material types:

- Concrete (even if it contains thick reinforcement steel)
- Sandstone and limestone
- All building materials for solid walls
- Asphalt floors

The core drills comply with the regulations issued by the "Stone and Earth" Professional Association issued in July 1989. They are machines of category II, which means that they must be placed on stands and be stable (pursuant to DIN 57100 or VDE 0100), the stand must be equipped with

- a reversing block, and
- a water suction device.

The machine must be connected to the 230 V mains

- direct using a personal safety switch (residual current-operated circuit-breaker or PRCD), or
- using a coded (1h) plug to a safety box (IP 44) with a residual current-operated circuit-breaker.

### 2.2 Safety



## Warning

**Before using the machine for the first time, check that the conformity of the data on the model plate with the mains voltage and frequency. Voltage deviations of  $\pm 5\%$  and/or voltage deviations of  $\pm 2\%$  are permissible. Repairs must only be completed by quality persons who have suitable training and qualifications.**

The following points are to be given special attention:

- the technical data and details of the permitted use of the machine (commissioning, ambient and operating conditions) which are set out in the catalogue, the operating manual, the model plate data and other product information,
- the relevant accident prevention regulations
- the correct use of tools
- the use of personal safety equipment

## 3.0 Transport and storage

### 3.1 Transport



## Warning

**The core drills are to be checked for signs for transport damage on receipt. Any damage must be documented in writing.**

### 3.2 Storage

If possible, the storage site should be dry, clean and have a constant temperature. To ensure that the film of lubricant in the bearings and sealing system is not lost, the motor shaft should be turned through several revolutions by hand after a lengthy period of storage, for example at monthly intervals. The roller bearings in the motors should be replaced (or regreased) if the period between delivery and commissioning is over four years. If the machines are stored in adverse conditions, this period may differ considerably.

## 4.0 Main dimensions and technical data

### 4.1 Dimensions

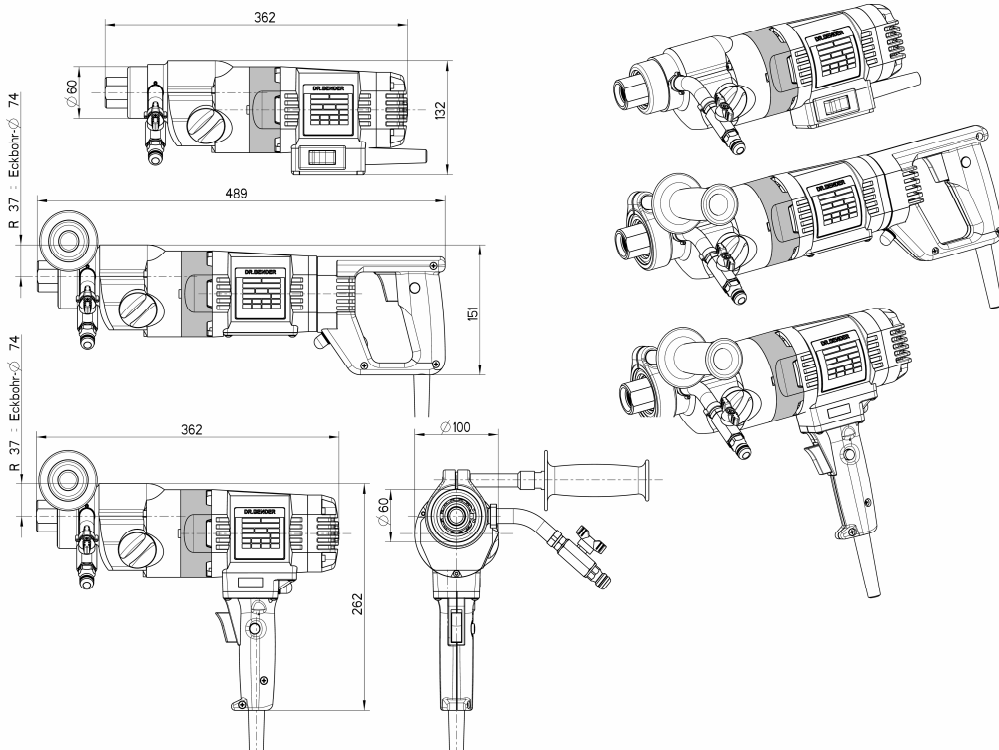

### 4.2 Technical Data

Rated Voltage	230	V
Current consumption	9	A
Power requirement	2200	W
Frequency	50 – 60	Hz
Idling speed	830 / 2200 / 4600	$min^{-1}$
Full speed	520 / 1400 / 2900	$min^{-1}$
Output rating	1300	W
Torque	27 / 12 / 6	Nm
Drilling diameter	15 – 150	mm
Weight EBM 33	4,5	kg
Weight EBM 33 S / EBM 33 F	5,2	kg
Core bit connection	UNC 1 ¼ / R ½	"
Overload coupling torque	12	Nm

### 4.3 Noise emissions and vibrations [EN 50144]

Noise level	Noise level	Vibration
dB(A)	dB	m/s <sup>2</sup>
88	101	< 2,5

## 5.0 Commissioning

Check that the mains voltage is identical with the voltage specified on the model plate.

Stand-mounted:

Secure the core drilling machine and the water collection device on the drill stand with a reverse lock. The drill stand should have high rigidity and precise, low-play guides. Ensure that the core drilling machine axis is parallel to the drill stand axis.

Insert the core bit and set the speed. Setting instructions are given on page 12.

Connect the water supply. Important: Do not exceed the max. water pressure of 3 bar.

Connect the core drilling machine to the mains via an RCCB box and a code plug 1 h or a PRCD safety switch.

Manually controlled:

When drilling a hole ensure that you are on a secure surface. Make particularly sure the core bit is not bent during the drilling process and hold the core drilling machine as rigid as possible. Concentrate hard on the work since if the core bit suddenly blocks, despite the low setting of the safety slip clutch, high forces may be generated. If you let go of the core drilling during the drilling process, you may suffer serious injury.

Only used three-core extension cables with a protective conductor and an adequate cross-section. If the cross-section is too low you may suffer excessive power loss and the motor and cable may overheat. An extension cable must be secured with an overload switch. Recommended cable cross-sections:

Rated current = 9 A							
Cable length	m	7.5	15	25	30	45	60
Cable cross-section	mm <sup>2</sup>	2.5	2.5	2.5	2.5	2.5	4

When drilling a hole ensure that you have sufficient cooling water. Only use clean tap water, do not use dirty or waste water. Adjust the supply to the core bit diameter and drive rating of the core drill so that you do not exceed the rated current.



## 5.1 Changing gear



### Warning

**Never change gear using force and only do so when the machine is slowing down or at a standstill.**

Move the gear switch handle by approx. 40° to the next higher or lower gear. If necessary (if it is difficult to engage the gear) turn the drive spindle briefly by hand until the gear engages easily. Never use tools (pliers, hammer, etc.) to change gear since otherwise gear damage will be inevitable.

## 5.2 Safety coupling

The values set out in the table are theoretical values and may be used to provide a rough guide for gear changing. Since a whole range of other parameters also plays a major role in adjusting the speed, we cannot offer any guarantee if the tool is damaged when using the values in the table. Drilling work for which the speeds are outside the range of the core drill (values printed in italics), should only be completed with extreme care and by trained personnel.

## 5.3 Core bits

All core bits with a connection thread of UNC 1 ¼" or R ½ " can be used.

Adapters can be supplied to allow core bits with other connection systems to be used.

Only use core bits that are suitable for the type of stone.

You will keep the core drill in good condition if you only use core bits that are concentric and not deformed ones.

Ensure that the diamond segments have an adequate undercut against the core bit body.



### Warning

**To use wrong tools or accessories is danger for your life.**

## 5.4 To change a core bit

The drill spindle has a right-handed thread.

Always use a 32 mm open-ended spanner to hold against the drill spindle.

Never release the core bit with (hammer) blows since this will damage the core drill.

The core bit can be removed more easily if you apply a little waterproof grease to the drill spindle thread.

## 6.0 Safety instructions



### Important

**Only use the core drill under supervision. Disconnect the mains plug and check that the switch has been turned off,**

- if you intend to leave the core drill unsupervised,
- for attachment and disconnection work,
- if the voltage drops (below 200 V),
- for adjustments or for fitting an accessory,

Switch off the machine if it stops for any reason. This will prevent its starting suddenly when it is not under supervision.

Do not use the tool if

- part of the casing is missing or defective,
- If water drips out of the overflow hole, stop work and have the core drill inspected by an authorised service contractor.
- Only drill above your head with suitable safety equipment (water collector), RCD and transformer protection class II.
- Connect dust extraction if required.
- After a fault do not switch on the machine again until the core bit can be turned easily.
- Check the area you wish to drill with a line detector to prevent drilling through electric cables, water or gas lines, etc.
- the switch, lead or plug connector has suffered damage (conduct a visual inspection every day).
- Cooling water must not be allowed to ingress into the motor or the electrical components when operating the core drill in any position.

Do not expose the tool to rain and use not in humidity or wet environment. Use a good lightning. Do not use the tool near flammable fluids or gase air mixes.

## 7.0 Servicing and care



### Warning

**Before starting any servicing or repair work always disconnect the mains plug. After all repairs you must have the core drilling machine inspected by an electrician (statutory regulation pursuant to VBG4 since 1.1.1990).**

### 7.1 Daily care

Ensure that no water escapes from the overflow hole. This will cause gear damage and may reduce the electrical safety of the core drilling machine. In this case please contact an authorised service centre.

Inspect the machine for signs of damage to the switch, mains lead or plug connector.

After completing the drilling work clean the core drilling machine. Grease the core bit mounting thread. The ventilation slits must be kept clean and open at all times. Ensure that no water gets into the core drilling machine whilst you are cleaning it.

To ensure that the sealing function is maintained, oil the drill spindle:

- Disconnect the core drilling machine from the water supply. Open the water connection shut-off cock and insert a drop of oil, close the shut-off cock, place a few drops of oil into the overflow hole and turn the machine briefly by hand.

### 7.2 After approx. 150 hours of use

After the first 150 hours of use, the gearbox oil must be changed.

### 7.3 After approx. 250 hours of use

Have the carbon brushes checked, and replaced if necessary, by an electrician.

- Remove the screws (at motor EBM33 pos. 37, at motor EBM33F pos. 47, at motor EBM33S pos. 35). Pull the cap (at motor EBM33 pos. 33, at motor EBM33F pos. 43, at motor EBM33S pos. 22) off the motor casing (2). Remove the carbon brushes screws (9), raise the carbon brushes retaining springs and take out the carbon brushes (7). Clean the carbon brush holder and collector with a paintbrush.
- Fit new carbon brushes following the above instructions in reverse. Position the cap (at motor EBM33 pos. 33, at motor EBM33F pos. 43, at motor EBM33S pos. 22) and secure it with the screws (at motor EBM33 pos. 37, at motor EBM33F pos. 47, at motor EBM33S pos. 35). Fit the cap (at motor EBM33 pos. 33, at motor EBM33F pos. 43, at motor EBM33S pos. 22) on the motor casing (2) by tapping it gently with a rubber mallet or the like. Tighten the screws (at motor EBM33 pos. 37, at motor EBM33F pos. 47, at motor EBM33S pos. 35). Release the stress by tapping the cap (at motor EBM33 pos. 33, at motor EBM33F pos. 43, at motor EBM33S pos. 22) twice.

Avoid adjusting the carbon retaining springs.

Only use original spare parts.

### 7.4 Quarterly

Have the cable, switch and plugs inspected by an expert (pursuant to VBG4) and document the process.

Replacing the gearbox oil will considerably extend the service life of the gear.

## 8.0 Speed adjustment dependent on the cutting speed

	3	4	5	6	7	[m/s]
15	3820	5093	6366	7639	8913	3rd gear
20	2900	3820	4775	5730	6685	3rd gear
25	2292	2900	3820	4584	5348	3rd gear
30	1910	2546	2900	3820	4456	3rd gear
35	1637	2183	2728	3274	3820	3rd gear
40	1400	1910	2387	2900	3342	3rd gear
45	1273	1698	2122	2546	2900	3rd gear
50	1146	1528	1910	2292	2674	2 or 3
55	1042	1400	1736	2083	2431	2 or 3
60	955	1273	1592	1910	2228	2 or 3
65	881	1175	1400	1763	2057	2 or 3
70	819	1091	1364	1637	1910	2 or 3
75	764	1019	1273	1528	1783	2 or 3
80	716	955	1194	1400	1671	2 or 3
85	674	899	1123	1348	1573	2 or 3
90	637	849	1061	1273	1485	2 or 3
95	603	804	1005	1206	1400	2nd gear
100	573	764	955	1146	1337	1 or 2
110	520	694	868	1042	1215	1 or 2
120	477	637	796	955	1114	1 or 2
130	441	588	735	881	1028	1 or 2
140	409	546	682	819	955	1 or 2
150	382	520	637	764	891	1 or 2
160	358	477	597	716	836	1 or 2
170	337	449	562	674	786	1 or 2
180	318	424	520	637	743	1st gear
190	302	402	503	603	704	1st gear
200	286	382	477	573	668	1st gear
210	273	364	455	546	637	1st gear
220	260	347	434	520	608	1st gear
230	249	332	415	498	581	1st gear
240	239	318	398	477	557	1st gear
250	229	306	382	458	535	1st gear
260	220	294	367	441	520	1st gear
<b>Bit capacity ø</b>		<b>concrete</b>	<b>concrete</b>	<b>rock</b>		
<b>[mm]</b>		<b>reinforced</b>				

The values set out in the table are theoretical values and may be used to provide a rough guide for gear changing. Since a whole range of other parameters also plays a major role in adjusting the speed, we cannot offer any guarantee if the tool is damaged when using the values in the table. Drilling work for which the speeds are outside the range of the core drill (values printed in italics), should only be completed with extreme care and by trained personnel.

## 9.0 Warranty

In keeping with our terms of sale, we offer a warranty for twelve months from the date of sale. This refers to the free repair of material and workmanship defects, which were verifiably caused before the sale.

An original purchase document must always be submitted in case of a warranty claim. It has to contain the full address of the dealer, the date of purchase and the type designation of the product. The operating instructions of the particular product and the safety instructions must have been followed.

Damages resulting from operational faults cannot be acknowledged as warranty cases.

The products of the manufacturer have been developed and produced for specific applications. No warranty claim is accepted in case of non-compliance with the due employment according to the operating instructions, in case of the employment for other purposes than originally intended or the employment of inadequate accessories.

The periodical maintenance and cleaning of the products according to the directions of the operating instructions is absolutely necessary. The intervention of third persons (opening the machine) renders any warranty claim void.

Maintenance and cleaning operations cannot be claimed on the basis of warranty.

Make sure only original spare parts and original accessories are used. They are available at the authorized specialized product dealer. If non-original parts are used, consequential damages and increased hazard cannot be ruled out. The producer is not liable for such damages. Disassembled or partially disassembled hand saws and those repaired with non-original parts are excluded from the warranty.

Certain components, such as carbon brushes, ball bearings, switches, power-supply lines, gaskets, etc., are exposed to usage dependent or to normal wear. These wearing parts are not object of this warranty. Wearing parts are marked on the spare parts lists.

## 10.0 General safety instructions

1. Read and follow these instructions before you use the tool. Keep these safety instructions in a safe place.
2. Keep your workplace tidy. Untidiness in the workplace can cause accidents.
3. Protect yourself from electric shocks. Refer to the applicable regulations. Avoid physical contact with earthed parts, such as pipes, heaters, furnaces and refrigerators.
4. Keep children away. Do not allow other people to touch the tool or cable, keep them away from where you are working.
5. Keep your tools in a safe place. Unused tools should be kept in a dry, locked room out of the reach of children.
6. Do not overload your tool. It will work better and more safely in the specified capacity range.
7. Use the correct tool. Do not use tools that are too weak or mounted tools for heavy work. Do not use tools for purposes and work for which they have not been designed.
8. Wear suitable clothing. Do not wear excessively baggy clothing or jewellery, which may be caught by moving parts. For working outdoors, we recommend the use of rubber gloves and sturdy shoes. Wear a hairnet if you have long hair.
9. Use goggles. Use a breathing mask for work that generates dust.
10. Do not use the cable for any purpose other than that for which it is designed. Do not carry the tool by the cable and do not use it to pull the plug out of the socket. Protect the cable from heat, oil and sharp edges.
11. Check the connection lead and plug every time before you use the tool for signs of damage. If they are damaged, have them replaced by a specialist. Always keep the connection lead away from the working area of the machine.
12. Secure the workpiece. Use clamps or a vice to hold the workpiece. This will make it more secure that if you hold it in your hand and will allow you to use both hands to control the machine.
13. Do not overstretch yourself. Avoid abnormal body positions. Ensure that you have a stable area on which to stand and keep your balance at all times.
14. Look after your materials with care. Keep your tools sharp and clean so that they produce good safe results. Check the plug and cable at regular intervals and have them replaced by a specialist if they suffer any damage. Check the extension cable at regular intervals and replace damaged cables. Keep the handles free of oil and grease.
15. Disconnect the mains plug from the supply when the tool is not in use and when changing the tool.
15. Do not leave a tool spanner on the tool. Before switching on the tool check that the wrench and setting tools have been removed.
16. Avoid the machine starting when you do not intend it to. Do not carry a tool that is connected to the mains supply with your finger on the switch. Ensure that the switch is turned off when you connect the tool to the mains supply.
18. Electric tools outdoors and in wet areas: Mobile tools which are used outdoors should be connected to the mains supply using a residual-current circuit breaker or the like for added safety. This is particularly important when working with freehand tools. If there is a water supply, you should use an isolation transformer and a voltage supply of 115 V; please specify in your order.
19. For outdoors work, only use extension cables, which are approved for this purpose and marked accordingly.
20. Be vigilant at all times. Watch your work. Proceed sensibly. Do not use the tool if you are not concentrating fully on what you are doing.
21. Important:  
Safety equipment (such as overcurrent protection devices, undervoltage trips, safety couplings etc.) are tools but do not offer guaranteed safety. As a responsible manufacturer we tailor these tools to each other so that they offer the best possible protection. But without the care and caution of the use, these tools may even cause damage if they are not used properly. Have the slip couplings, in particular, checked during the quarterly inspection to ensure that it is correctly adjusted and functions properly. This inspection should be conducted by the manufacturer or an authorised service outlet and documented.

22. Check the machine every day for signs of damage, conduct a visual inspection:  
Before reusing the tool, carefully check the safety equipment or slightly damaged parts to ensure that they offer perfect and proper function. Check that all moving parts function correctly, that they do not jam and that none of the parts are damaged. All parts must be correctly fitted and satisfy all the conditions to ensure the perfect operation of the tool. Damaged safety equipment and parts must be repaired or replaced properly by a specialist service contractor. Do not use any tools, which cannot be switched on and off using the switch. Pay particular attention to ensuring electrical safety: Cables? Plugs? Switches? Do all the components satisfy safety regulations?
23. Repairs may only be completed by trained personnel. Before being used for the first time and after all repair work, the safety of electric tools must be checked by an electrician pursuant to VBG 4, § 5. This inspection must also be conducted and documented at regular intervals – at least once per year.
24. Please note that as the operator you are responsible for complying with any additional regulations. For example if electric tools are used in a wet and/or damp environment, the regulations of the "Stone and Earth" Professional Association must be satisfied.
25. Electrical safety and fire safety: We now also recommend the additional safety and fire safety for all out tools, as set out in the new version of VDE 0100 which can be achieved by using low cost residual current-operated circuit-breakers or DI/PRCD switches.

## 11.0 Spare parts list

### 11.1 Stone drilling machine complete EBM33

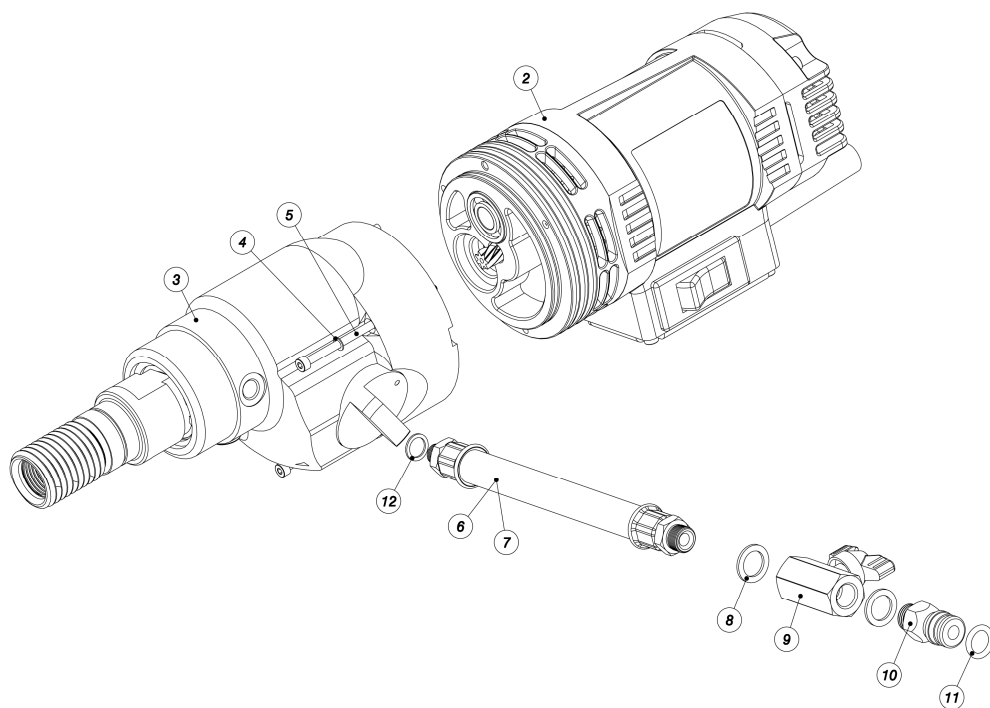



Item	Art. No.	Description	No.
1	200940	Stone drilling machine complete EBM33	1
2	200939	Motor complete	1
3	300887	Gear complete	1
4	800076	Locking washer	3
5	901012	Hexagon socket head cap screw	3
6	802980	Water connection complete	1 **
7	802981	Hose complete	1
8	800028	Sealing ring	1
9	800023	Ball cock complete	1
10	800020	Slot-in nipple	1
11	800040	O ring	1
12	800027	Sealing ring	1

Wearing parts\*\*

## 11.2 Stone drilling machine complete EBM33 F

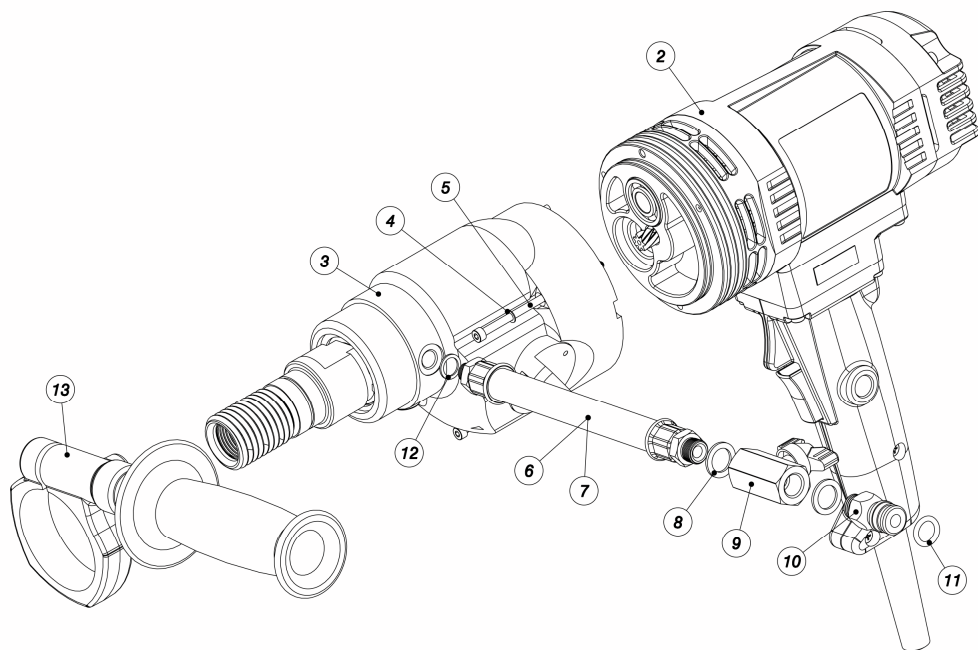

Item	Art. No.	Description	No.
1	200942	Stone drilling machine complete EBM33 F	1
2	200941	Motor complete	1
3	300887	Gear complete	1
4	800076	Locking washer	3
5	901012	Hexagon socket head cap screw	3
6	802980	Water connection complete	1 **
7	802981	Hose complete	1
8	800028	Sealing ring	1
9	800023	Ball cock complete	1
10	800020	Slot-in nipple	1
11	800040	O ring	1
12	800027	Sealing ring	1
13	400961	Handle complete	1
			Wearing parts**

## 11.3 Stone drilling machine complete EBM33 S

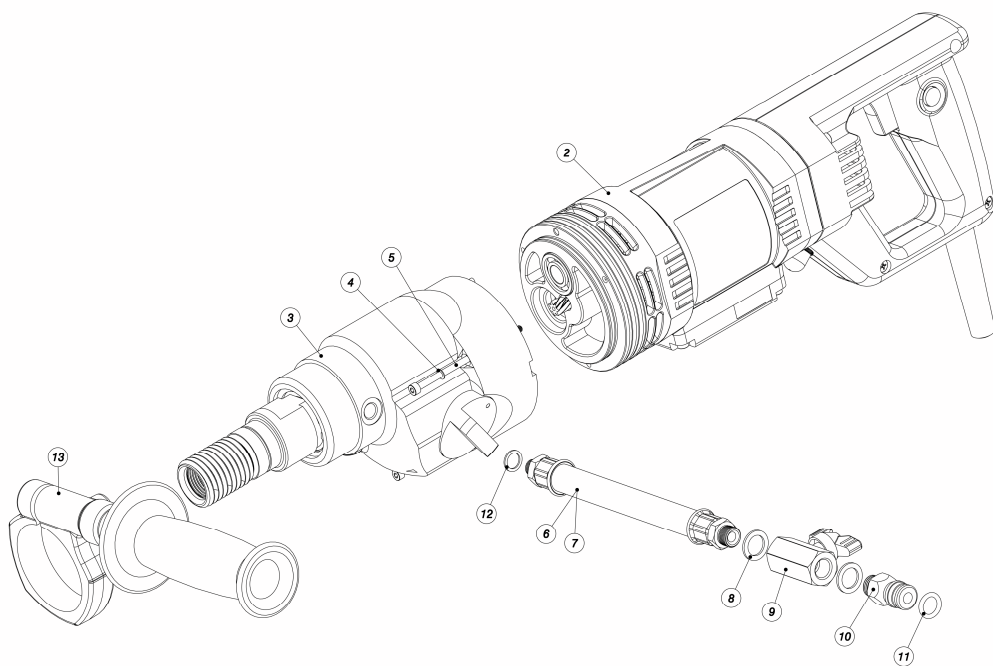

Item	Art. No.	Description	No.
1	200944	Stone drilling machine complete EBM33 S	1
2	200943	Motor complete	1
3	300887	Gear complete	1
4	800076	Locking washer	3
5	901012	Hexagon socket head cap screw	3
6	802980	Water connection complete	1 **
7	802981	Hose complete	1
8	800028	Sealing ring	1
9	800023	Ball cock complete	1
10	800020	Slot-in nipple	1
11	800040	O ring	1
12	800027	Sealing ring	1
13	400961	Handle complete	1
			Wearing parts**

# 11.4 Motor complete EBM 33

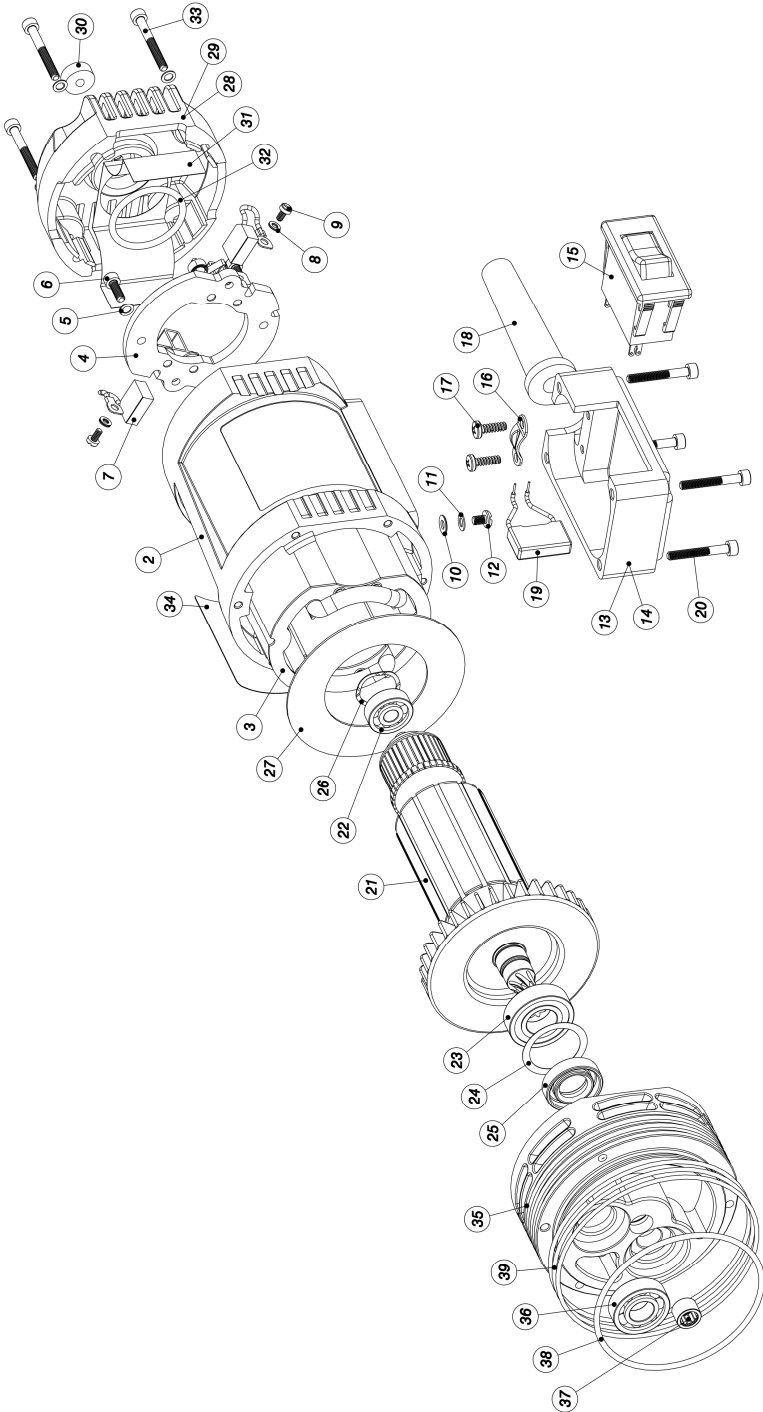

Item	Art. No.	Description	No.
1	200939	Motor complete	1
2	200397	Motor casing	1
3	401300	Magnet casing	1
4	400888	Brush bridge	1
5	800076	Locking washer	6
6	900339	Hexagon socket head cap screw	2
7	800948	Carbon brush	2 **
8	900183	Spring washer	4
9	900407	Cheese-head screw	2
10	900231	Washer	1
11	900181	Spring washer	1
12	900412	Flat head screw	1
13	300892	Switch box complete	1
14	300891	Switch box	1
15	801309	Toggle switch	1
16	801221	Strain-relief clamp	1
17	900699	Cross recessed pan head tapping screw	2
18	801222	Cable grommet	1 **
19	801220	Interference-suppression capacitor	1
20	900337	Hexagon socket head cap screw	4
21	401042	Balanced armature with fan	1
22	900001	Grooved ball bearings	1 **
23	900483	Grooved ball bearings	1 **
24	801988	Shim ring	1
25	900708	Shaft sealing ring	1 **
26	800266	Ball bearing compensating disc	1
27	401666	Air-flow-plate	1
28	401099	Bearing cap complete	1
29	200549	Bearing cap	1
30	800910	Spirit level	1
31	401098	Insulation	1 **
32	800089	O ring	1 **
33	900756	Hexagon socket head cap screw	4
34	801017	Information plate	1
Item	Art. No.	Description	No.
35	201049	Intermediate cover	1
36	900495	Grooved ball bearings	1 **
37	900170	Needle sleeve	1 **
38	800099	O ring	1 **
39	801346	O ring	3 **

Wearing parts\*\*

# 11.5 Motor complete EBM 33 F

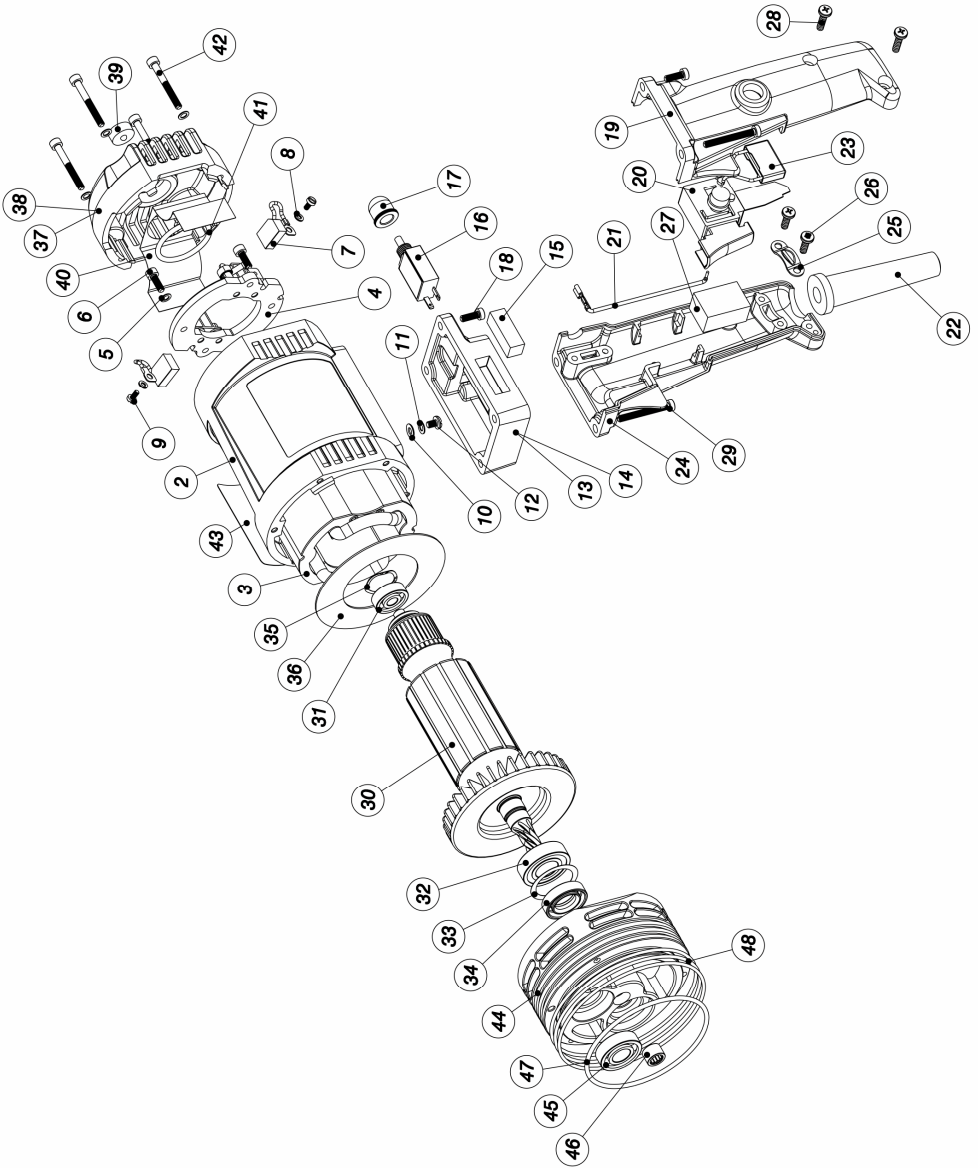



Item	Art. No.	Description	No.
1	200941	Motor complete	1
2	200397	Motor casing	1
3	401300	Magnet casing	1
4	400888	Brush bridge	1
5	800076	Locking washer	6
6	900339	Hexagon socket head cap screw	2
7	800948	Carbon brush	2 **
8	900183	Spring washer	4
9	900407	Cheese-head screw	2
10	900231	Washer	1
11	900181	Spring washer	1
12	900412	Flat head screw	1
13	401101	Control box complete	1
14	401100	Control box	1
15	801200	Spirit level	1
16	800139	Circuit breaker	1
17	800134	Protecting cap	1 **
18	900689	Hexagon socket head cap screw	4
19	801211	Handle half	1
20	801308	Equipment switch	1
20	801219	Equipment switch – electronic optional	1
21	801239	Cable complete	1
22	801222	Cable grommet	1 **
23	801220	Interference-suppression capacitor	1
24	801210	Handle half	1
25	801221	Strain-relief clamp	1
26	900699	Cross recessed pan head tapping screw	2
27	801074	Softpack	1
28	900623	Cross recessed pan head tapping screw	2
29	901405	Hexagon socket head cap screw	2
30	401042	Balanced armature with fan	1
31	900001	Grooved ball bearings	1 **
32	900483	Grooved ball bearings	1 **
33	801988	Shim ring	1
34	900708	Shaft sealing ring	1 **
35	800266	Ball bearing compensating disc	1
36	401666	Air-flow-plate	1
37	401099	Bearing cap complete	1
38	200549	Bearing cap	1
39	800910	Spirit level	1
40	401098	Insulation	1 **
41	800089	O ring	1 **
42	900756	Hexagon socket head cap screw	4
43	801017	Information plate	1
Item	Art. No.	Description	No.
44	201049	Intermediate cover	1
45	900495	Grooved ball bearings	1 **
46	900170	Needle sleeve	1 **
47	800099	O ring	1 **
48	801346	O ring	3 **

Wearing parts\*\*

# 11.6 Motor complete EBM 33 S

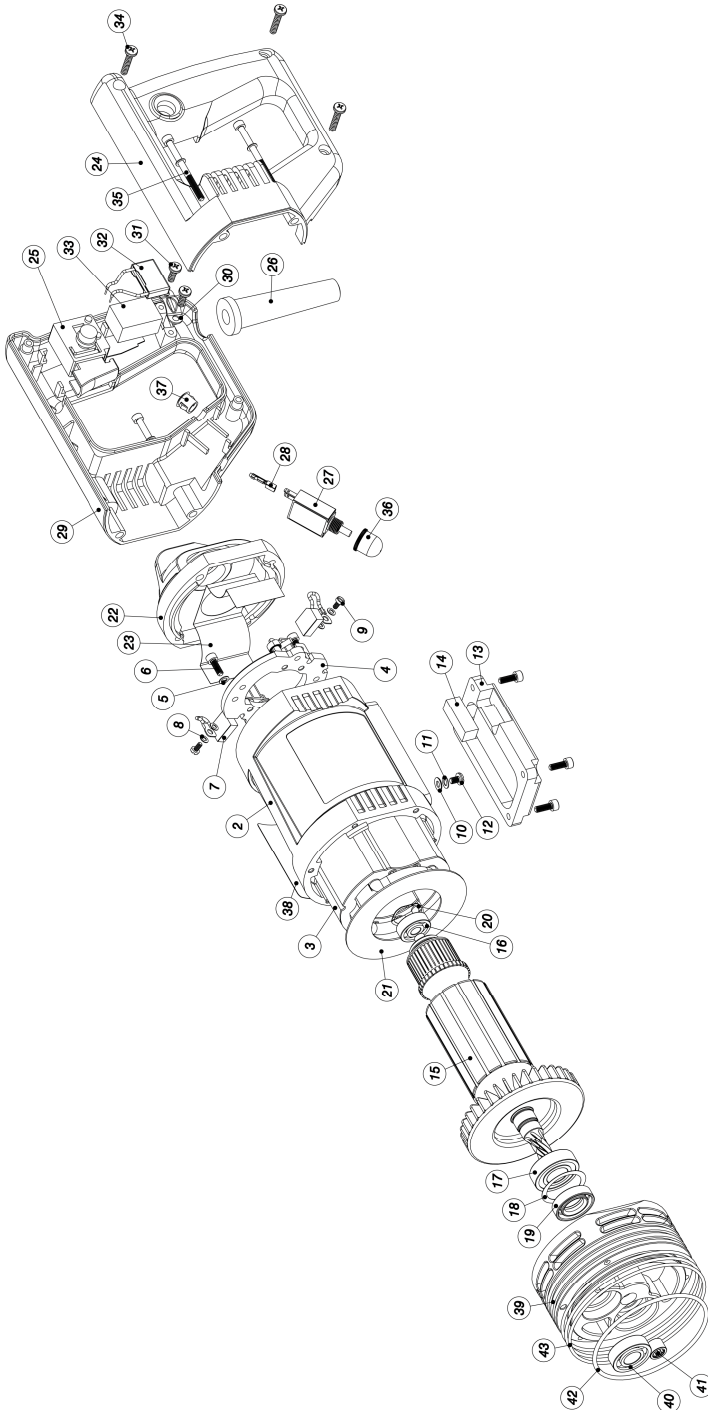

Item	Art. No.	Description	No.
1	200943	Motor complete	1
2	200397	Motor casing	1
3	401300	Magnet casing	1
4	401315	Brush bridge	1
5	800076	Locking washer	6
6	900339	Hexagon socket head cap screw	6
7	800948	Carbon brush	2 **
8	900183	Spring washer	4
9	900407	Cheese-head screw	2
10	900231	Washer	1
11	900181	Spring washer	1
12	900412	Flat head screw	1
13	301075	Switch box cover	1
14	801200	Spirit level	1
15	401042	Balanced armature with fan	1
16	900001	Grooved ball bearings	1 **
17	900483	Grooved ball bearings	1 **
18	801988	Shim ring	1
19	900708	Shaft sealing ring	1 **
20	800266	Ball bearing compensating disc	1
21	401666	Air-flow-plate	1
22	200569	Cap	1
23	401098	Insulation	1 **
24	801225	Handle left	1
25	801224	Equipment switch	1
26	801222	Cable grommet	1 **
27	800139	Circuit breaker	1
28	801364	Cable complete	1
29	801226	Handle right	1
30	801221	Strain-relief clamp	1
31	900699	Cross recessed pan head tapping screw	2
32	801220	Interference-suppression capacitor	1
33	801074	Softpack	1
34	900698	Cross recessed pan head tapping screw	3
35	900704	Hexagon socket head cap screw	4
36	800134	Protecting cap	1 **
37	801361	Cover plate	1
38	801017	Information plate	1
Item	Art. No.	Description	No.
39	201049	Intermediate cover	1
40	900495	Grooved ball bearings	1 **
41	900170	Needle sleeve	1 **
42	800099	O ring	1 **
43	801346	O ring	3 **

Wearing parts\*\*

# 11.7 Gear complete

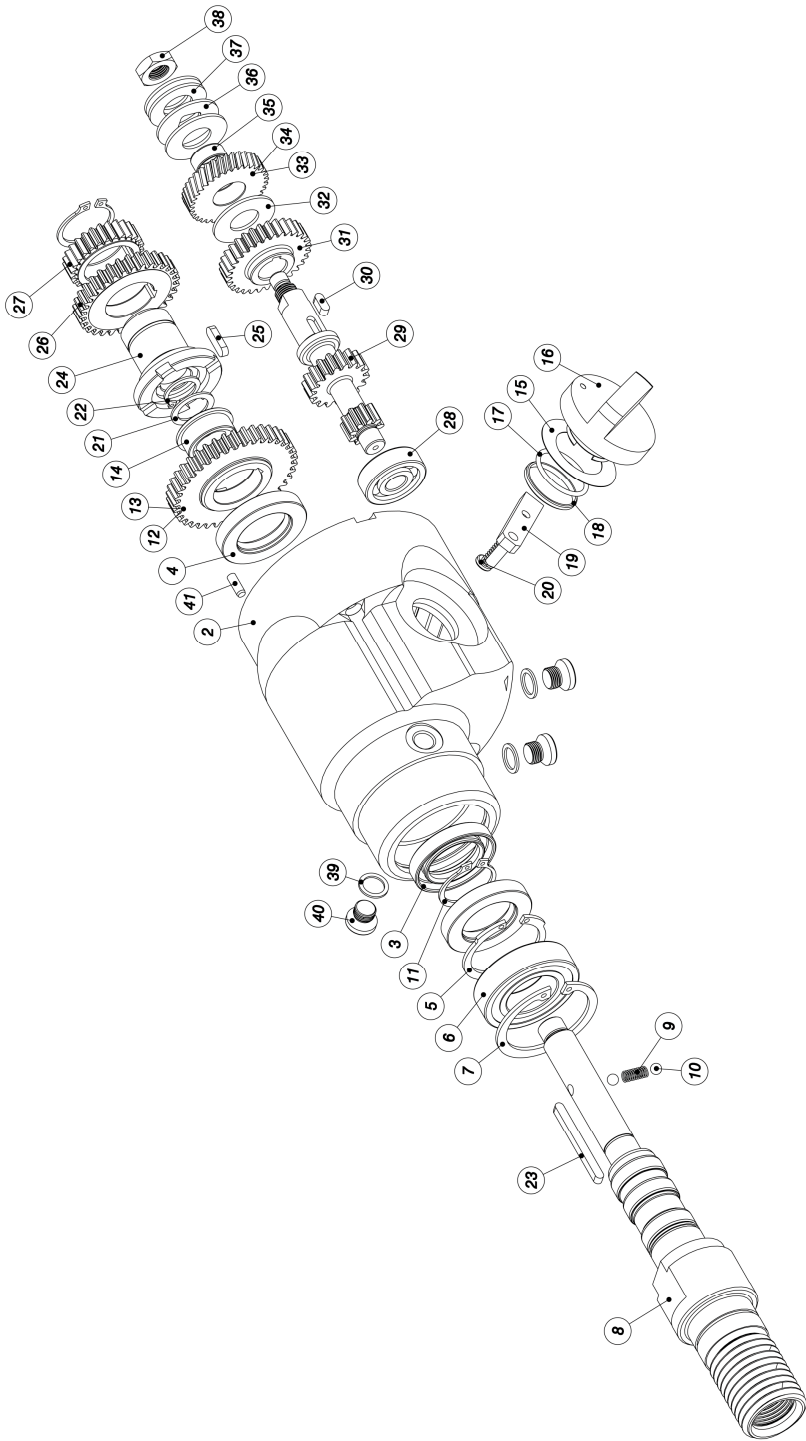

Item	Art. No.	Description	No.
1	300887	Gear complete	1
2	200570	Gear casing	1
3	900020	Shaft sealing ring	1 **
4	900019	Shaft sealing ring	2 **
5	800001	Locking ring	1 **
6	900000	Grooved ball bearing	1 **
7	800559	Locking ring	1 **
8	301213	Drill spindle complete, 1 ¼" / R ½" optional	1
9	900013	Compression spring	1
10	900014	Ball	2
11	800000	Locking ring	2 **
12	401104	Loose wheel complete	1
13	300774	Control wheel / Loose wheel	1
14	401105	Bearing sleeve	1 **
15	800483	Compensation slice	1
16	100723	Control grip	1 **
17	801367	O ring	1 **
18	401038	Sleeve	1
19	401036	Switch handle complete	1
20	801755	Slotted cheese head screws	1
21	900560	Adjusting washer	1
22	800002	Spring ring	1
23	900764	Parallel key	1
24	300882	Control connector	1
25	900765	Parallel key	1
26	300775	Control wheel 2	1
27	300883	Control wheel 3	1
28	900486	Grooved ball bearing	1 **
29	300888	Reduction shaft	1
30	900127	Parallel key	1
31	300889	Speed wheel 3	1
32	400135	Brake disc	2 **
33	401040	Reduction wheel complete	1
34	300780	Reduction wheel	1
35	401041	Bearing sleeve	1 **
36	400137	Compression washer	1
37	900018	Disc spring	2
38	900008	Hexagonal nut	1 **
39	800027	Sealing ring	3 **
40	800026	Sealing screw	3
41	900012	Cylindrical pin	1
42	801019	Gearbox oil 0,3 l	1 **

Wearing parts\*\*

# 11.8 Connection cables and accessories

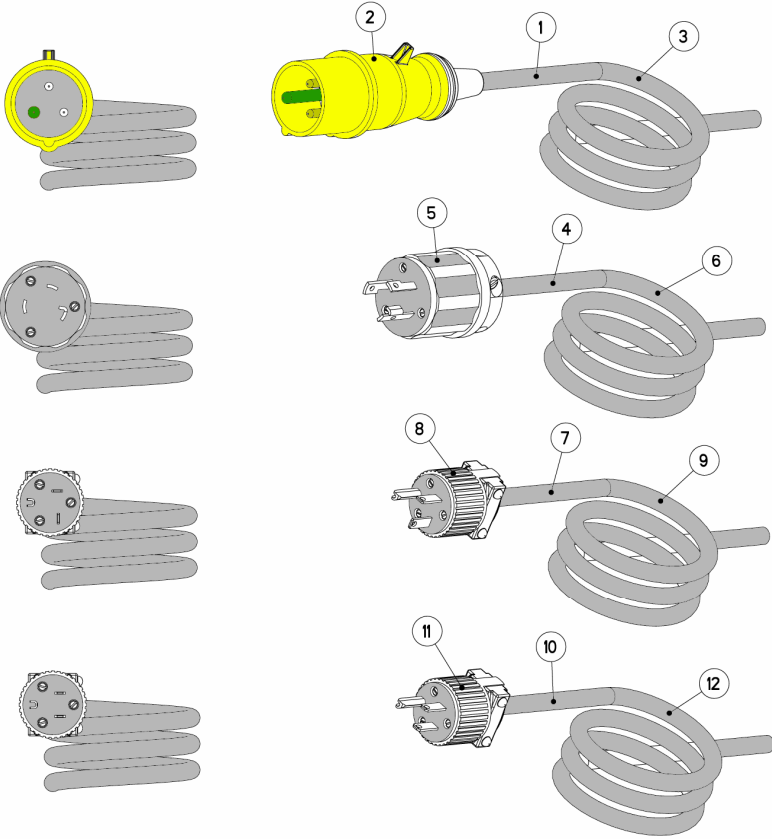

Item	Article number	Description	No.
<b>Plugs for UK and standards for type EBM</b>			
1	801462	Connection cable compl. 4h	1
2	900159	Plug, 4h	1
3	801328	Connection cable, finished	1
<b>Plugs for UK and standards for type BBM</b>			
1	801460	Connection cable compl. 4h	1
2	900159	Plug, 4h	1
3	801459	Connection cable, finished	1
<b>Plugs for USA and Japan up to 30 amps for type BBM</b>			
4	801321	Connection cable compl.	1
5	801317	Plug, 30A	1
6	801320	Connection cable, finished	1
<b>Plugs for USA and Japan up to 20 amps for type EBM</b>			
7	801461	Connection cable compl.	1
8	800200	Plug, 15A	1
9	801328	Connection cable, finished	1
<b>Plugs for USA and Japan up to 20 amps for type EBL</b>			
7	803182	Connection cable compl.	1
8	800168	Plug, 20A	1
9	801328	Connection cable, finished	
<b>Plugs for Australia</b>			
10	802839	Connection cable compl.	1
11	801809	Plug, 15A	1